

California Solar Initiative (CSI) Thermal Program Metering Installation Guide

Purpose: The purpose of this metering installation guide is to provide participating eligible contractors in the CSI-Thermal Program with information on correct metering configurations and installation for the three metering and monitoring purposes: Customer Performance Monitoring (CPM), Opt-in Measurement and Evaluation (M&E) and 70/30 True-up Payments. A symbol legend may be found on the last page of this document to assist with interpreting the following schematics.

1. Customer Performance Monitoring (CPM)

For CPM, metering either the collector loop or the potable water side are both acceptable, as described in sections 1.1 and 1.2 below.

1.1 Configuration 1: Customer Performance Monitoring- Collector Loop: A BTU meter may be installed on the collector loop as shown.

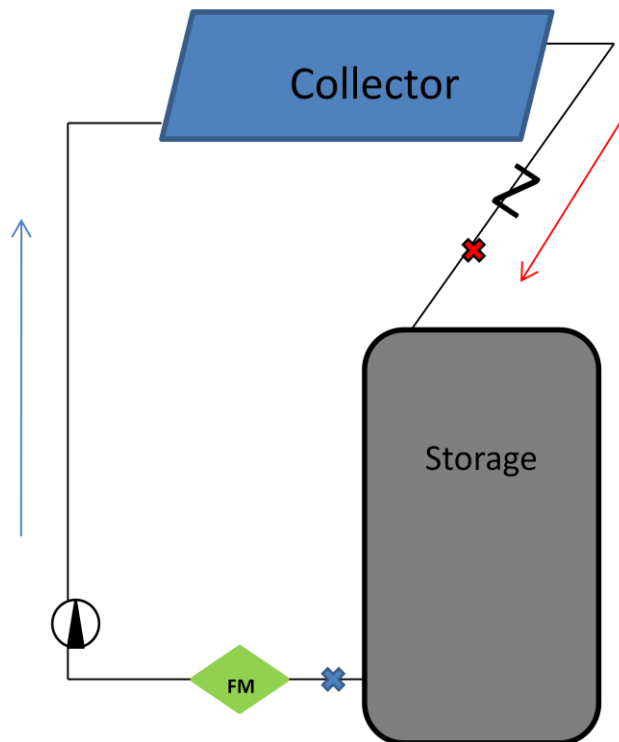

1.2 Customer Performance Monitoring- Potable Water Side: Any of the potable water side metering may be used as shown in configurations 2-12 below.

2. Acceptable Metering Points (M&E and 70/30 True Up)

The flow meter, cold sensor and the hot sensor must be located on the potable water plumbing pipe that records identical flow rates (GPM) for the flow meter and the hot sensor, in order to avoid distorted calculations of Btu's. The location of the mixing valve (between the tank and the back-up heater or after the back-up heater) creates branches of water that have different flow rates. If the hot

sensor is placed on the wrong branch, with different flow than the cold sensor/flow meter, the calculation of Btu's will be erroneous. BTU meters shall accumulate, store and communicate BTU's and gallons. Flow meters must also be installed in the cold supply pipe in locations that are not affected by recirculation return, as shown in the attached schematics.

2.1 Configuration 2: Two tank fluid system with recirculation returning to backup heater, no recirculation, and a mixing valve after the backup water heater. Place the flow meter and cold sensor on the cold city supply pipe downstream from the branch to the mixing valve. Place the hot sensor on the pipe between the solar tank and the backup water heater.

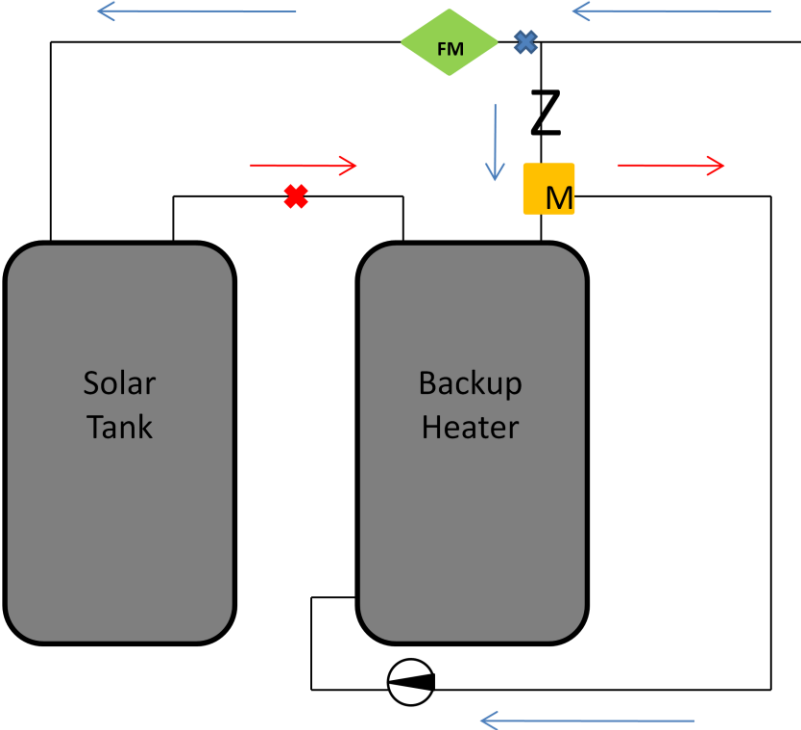

2.2 Configuration 3: Two tank fluid system with no recirculation or with recirculation returning to backup heater and a mixing valve between the solar tank and the backup water heater. Place the flow meter and cold sensor on the cold city supply pipe upstream (before) from the branch to the mixing valve. Place the hot sensor on the pipe between the mixing valve and the backup water heater.

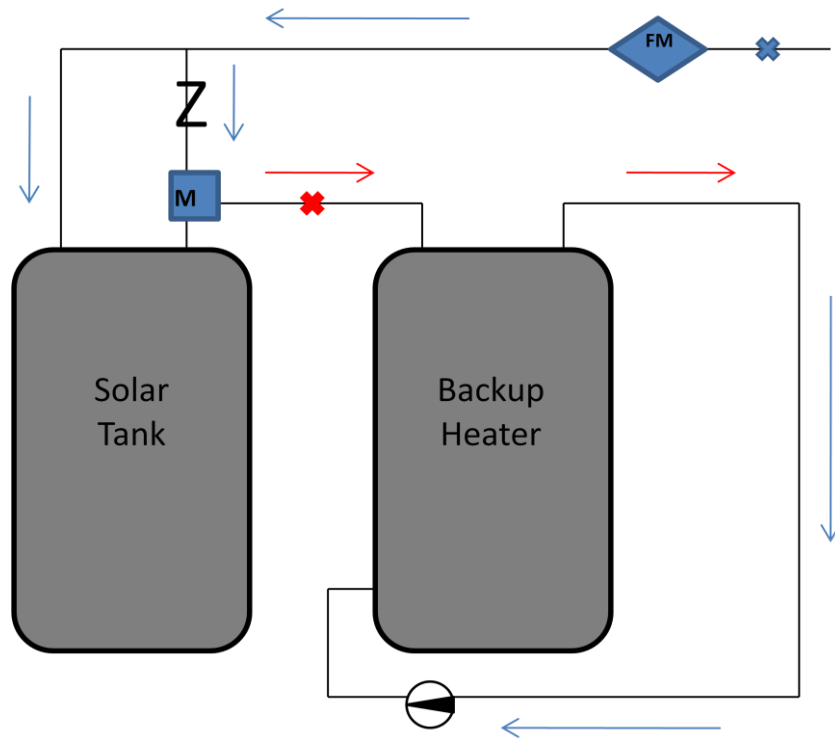

Note: Local code authority may require a mixing or anti-scald valve after the backup heater.

2.3 Configuration 4: Two tank fluid system, recirculation return to backup water heater with diverter valve and control diverting recirculation return to the solar tank, mixing valve after the backup water heater. Place the flow meter and cold sensor on the cold city supply pipe downstream from (after) the tee from the recirculation return diverter valve. Place the hot sensor on the pipe between the solar tank and the backup water heater. The BTU meter must be able to register negative BTUs, that is BTU's contributed by the backup water heater when the recirculation return water is hotter going into the solar tank than that passing from the solar tank into the backup water heater. This is done by subtracting BTUs from the cumulative total whenever the temperature of the hot sensor exceeds the temperature of the cold sensor. Place a second flow meter on the cold city supply pipe upstream from (before) the branch to the mixing valve.

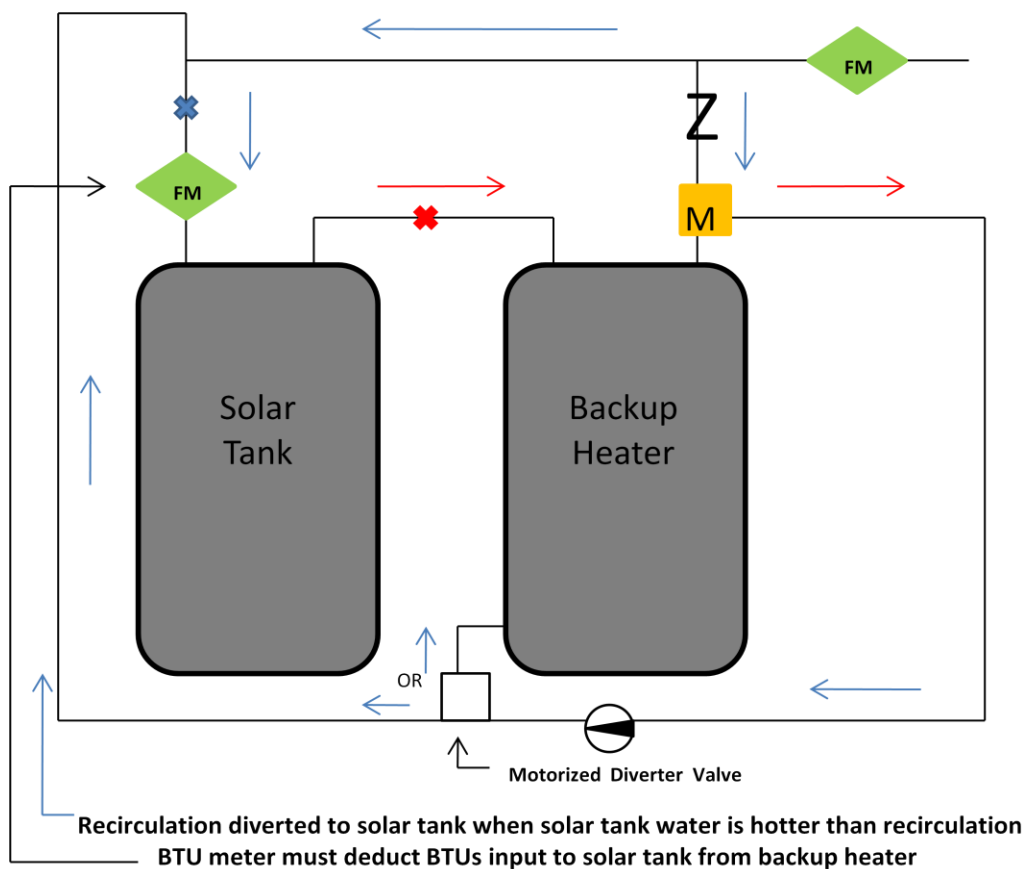

Note- Use BTU flow meter rated for the temperature of recirculation return warm water.

2.4 Configuration 5: One tank fluid system, mixing valve, recirculation or no recirculation. Solar external or internal heat exchanger, or no heat exchanger. Place a flow meter and cold sensor on the cold city supply pipe leading into the tank. Place the hot sensor on the hot out pipe from the backup water heater. Place a gas meter on the backup heater gas line or if electric backup, place an electric meter on the electric backup water heater heating element. Send gas/electric usage signals to the same monitoring data provider as the BTU meter data.

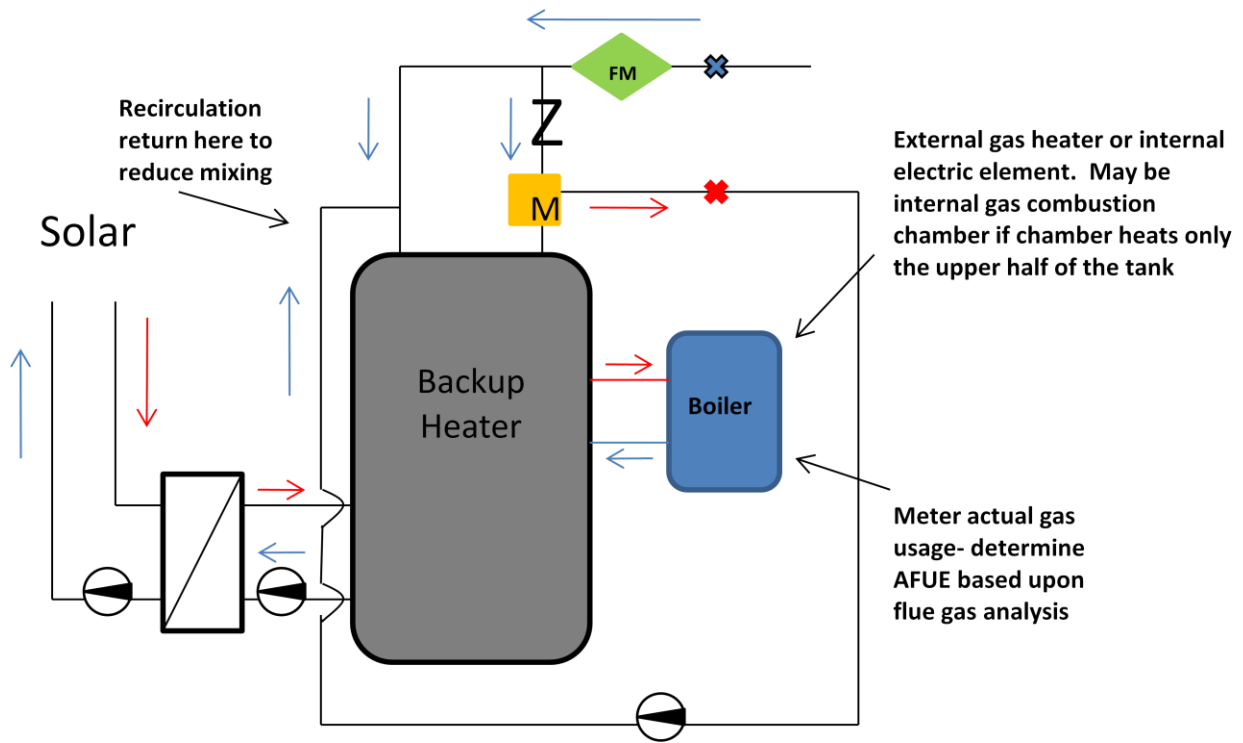

2.5 Configuration 6: Two tank fluid system, recirculation return to backup water heater, one mixing valve between the solar tank and the backup water heater, and one mixing valve downstream from (after) the backup water heater. Place the flow meter and cold sensor on the city cold supply pipe between the two branches to the mixing valves. Place the hot sensor on the pipe between the solar tank mixing valve and the backup water heater.

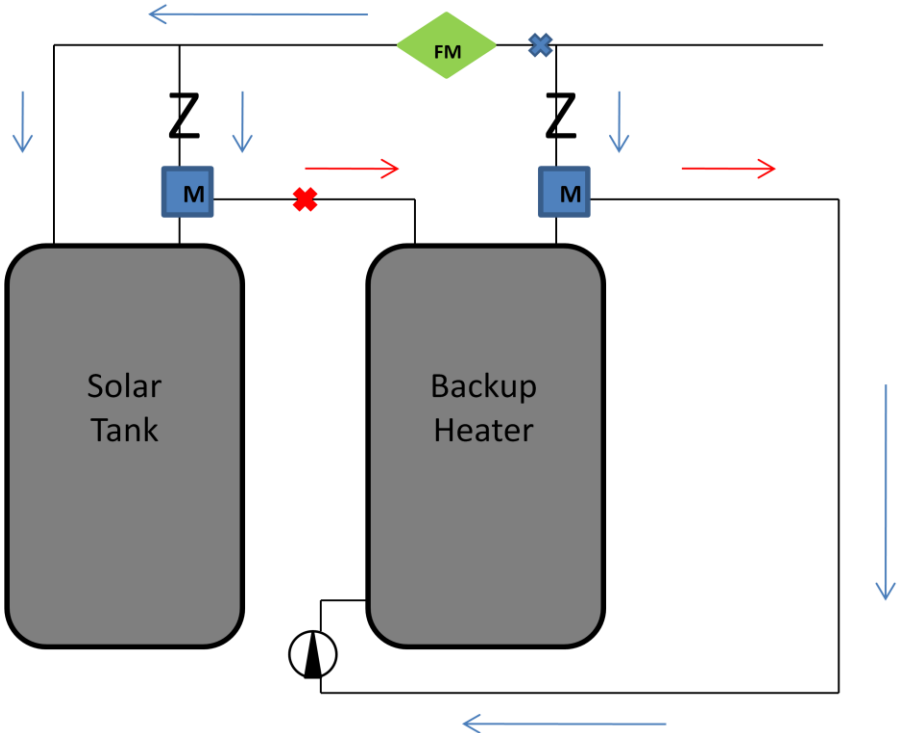

2.6 Configuration 7: Two tank fluid system, recirculation return to backup water heater with diverter valve and control diverting recirculation return to the solar tank, mixing valve between the solar tank and the backup water heater. Place the flow meter and cold sensor on the cold city supply pipe downstream from (after) the tee from the recirculation return diverter valve. Place the hot sensor between the mixing valve and the backup water heater. The BTU meter must be able to register negative BTUs, that is BTU's contributed by the backup water heater when the recirculation return water is hotter going into the solar tank than that passing from the solar tank into the backup water heater. Place a separate flow meter on the cold city supply to measure total hot water flow.

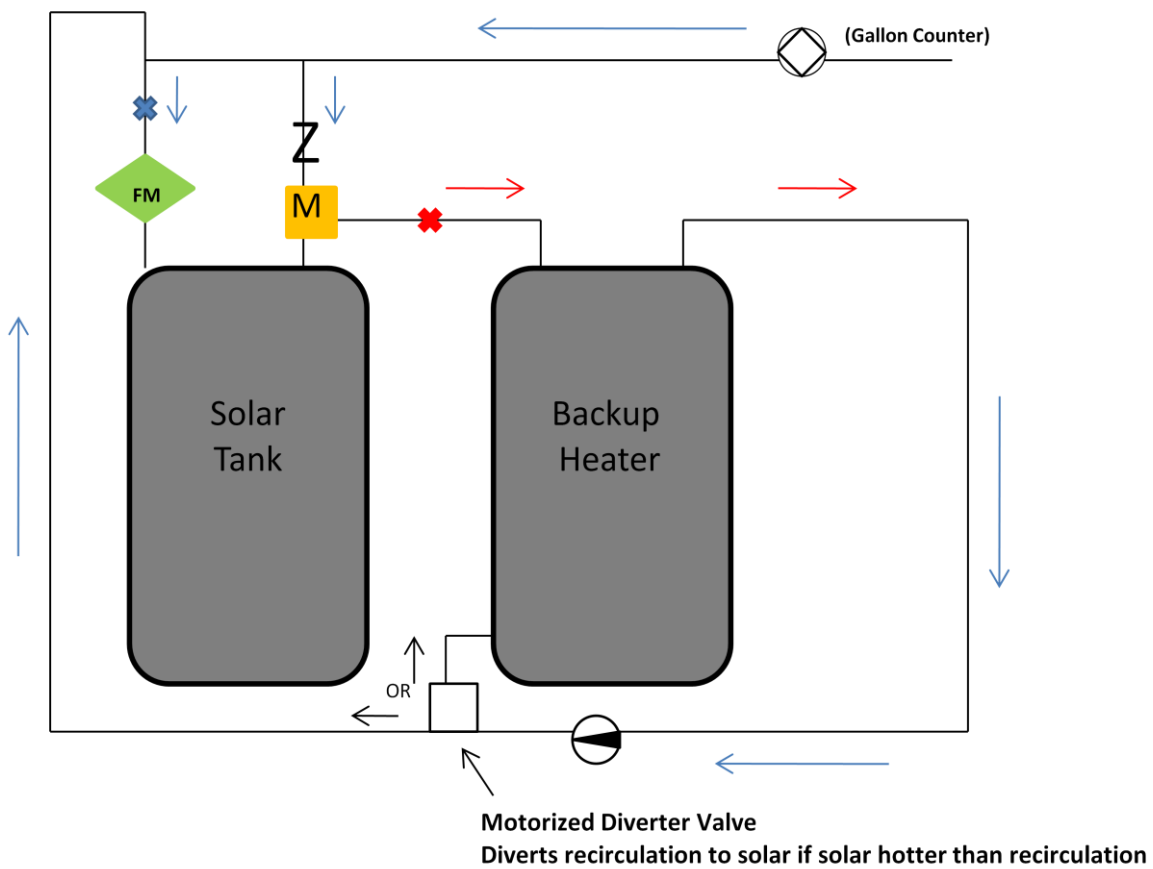

2.7 Configuration 8: Two tank fluid system, recirculation return to backup water heater with diverter valve and control diverting recirculation return to the solar tank, mixing valve between the solar tank and backup heater, and a second mixing valve after the backup water heater. Place the flow meter and cold sensor on the cold city supply pipe downstream from (after) the tee from the recirculation return diverter valve. Place the hot sensor on the pipe between the solar tank and backup heater. The BTU meter must be able to register negative BTUs, that is BTU's contributed by the backup water heater when the recirculation return water is hotter going into the solar tank than that passing from the solar tank into the backup water heater. Place a separate flow meter counter on the city cold supply between the branches to the two mixing valves.

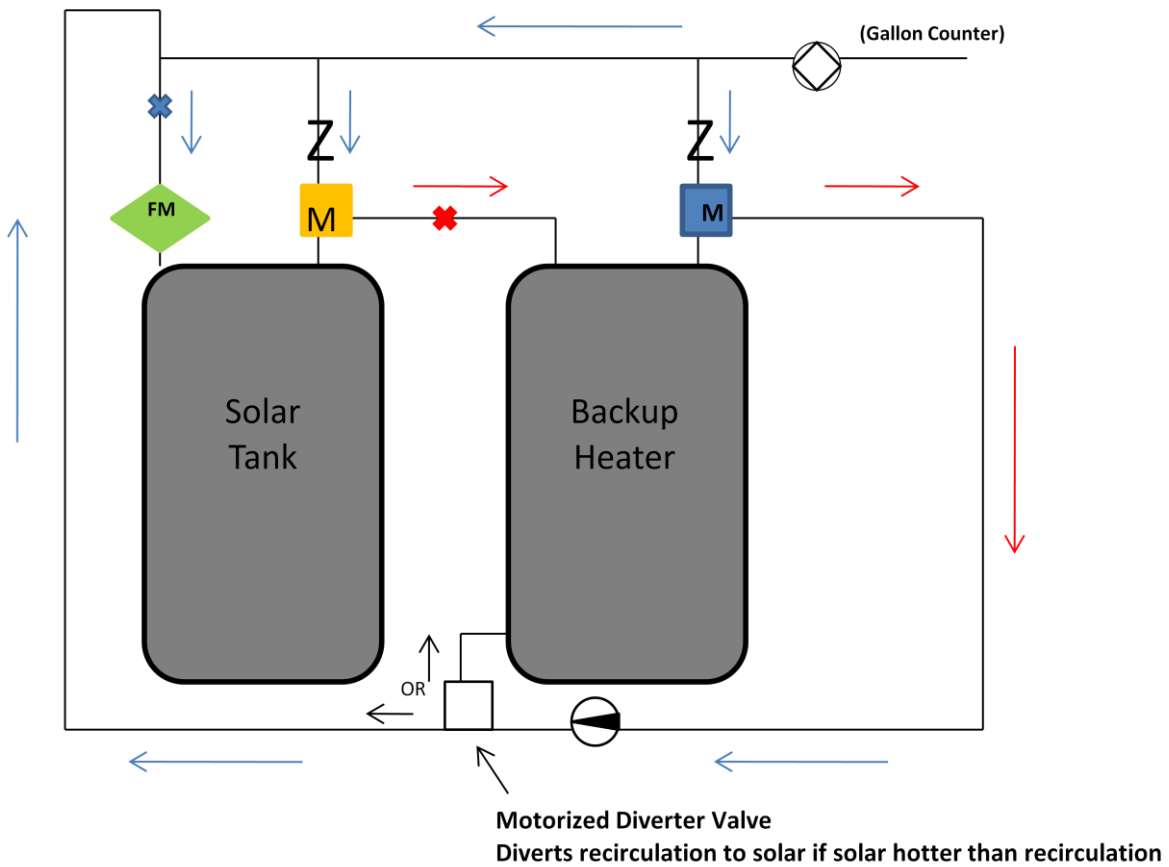

2.8 Configuration 9: Two tank drain back fluid system, recirculation return to backup water heater with diverter valve and control diverting recirculation return to the solar tank, mixing valve after the backup water heater. Place the flow meter and cold sensor on the cold city supply pipe downstream from (after) the tee from the recirculation return diverter valve into the solar tank. Place the hot sensor on the pipe between the solar tank and the backup heater. The BTU meter must be able to register negative BTUs, that is BTU's contributed by the backup water heater when the recirculation return water is hotter going into the solar tank than that passing from the solar tank into the backup water heater.

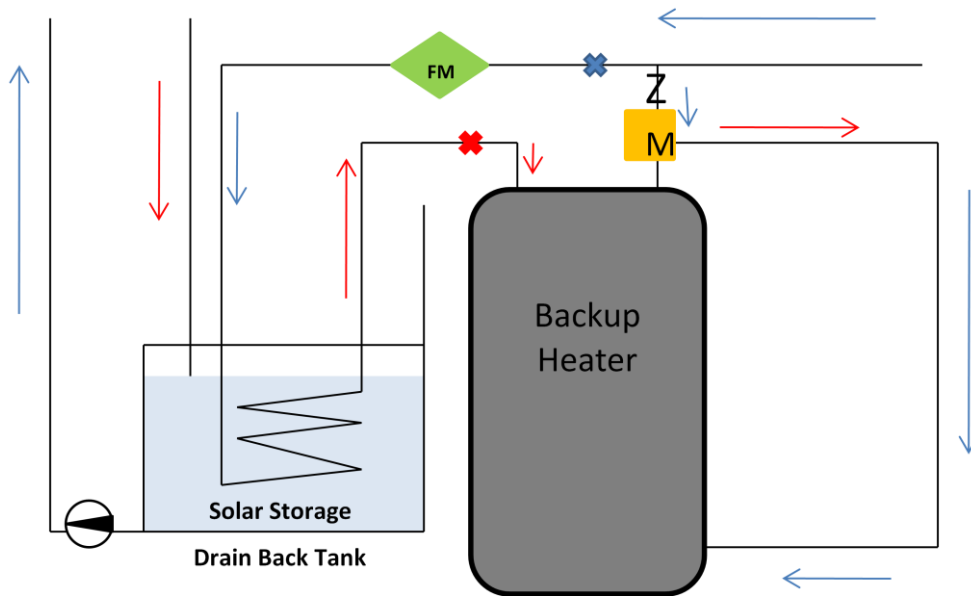

Note regarding drain back systems:







Whether the drain back reservoir is small (as with residential systems, feeding a solar storage tank) or large (as with large systems, providing storage as well as drain back reservoir), treat the system as a two-tank system for purposes of positioning the BTU meter and sensors.

If both solar and conventional energy (gas or electric) heat the same storage tank, treat as a one-tank system, even if the drain back reservoir is sized to contain the water in the collectors and piping (but no more).

2.9 Air Systems: Treat as a configuration 5 one tank system, section 2.4.

2.10 ICS TS Fluid System: Treat as one or two tank, depending on the existence of mixing valve or recirculating system.

Legend:

	Hot Sensor
	Cold Sensor
	Pump
	Mixing Valve
	Flow Meter
	Flow Meter Counter